

Service Schematics

NOKIA 6290

RM-176

Introduction

Important:

This document is intended for use by authorized service centers only.

“Service Schematics” was created with focus on customer care.
The purpose of this document is to provide further technical repair information for NOKIA mobile phones on Level 3/4 service activities.
It contains additional information such as e.g. “Component finder”,
“Frequency band table” or “Antenna switch table”.
The “Signal overview” page gives a good and fast overview about the most important signals and voltages on board.
Saving process time and improving the repair quality is the aim of this document.
It is to be used additionally to the service manual and other training or service information such as Service Bulletins.

All measurements were made using following equipment:

Nokia repair SW	:	Phoenix version 2006.44.6.163
Oscilloscope	:	Fluke PM 3380A/B
Spectrum Analyzer	:	Advanced R3162 with an analog probe
RF-Generator/GSM Tester	:	Rhode & Schwarz CMU 200
Multimeter	:	Fluke 73 Series II



Table of contents

Frontpage	1
BETTY, AV con, Mini USB, Charger jack	2
AVILMA, BTHFM, SIM, Audio	3
RAPIDO, Combo , Micro, microSD, IrDA	4
User Interface	5
LCD PWB, Earpeace	6
Camera	7
RF part	8
Signal overview	9
Component finder	10
Component finder LCD PWB	11

While every endeavour has been made to ensure the accuracy of this document, some errors may exist. If the reader finds any errors, NOKIA should be notified in writing.

Please send E-Mail to: training.sace@nokia.com

Copyright © NOKIA

This material, including documentation and any related computer programs is protected by copyright, controlled by NOKIA. All rights are reserved. Copying, including reproducing, modifying, storing, adapting or translating any or all of this material requires the prior written consent of NOKIA. This material also contains confidential information, which may not be disclosed to others without the prior written consent of NOKIA.

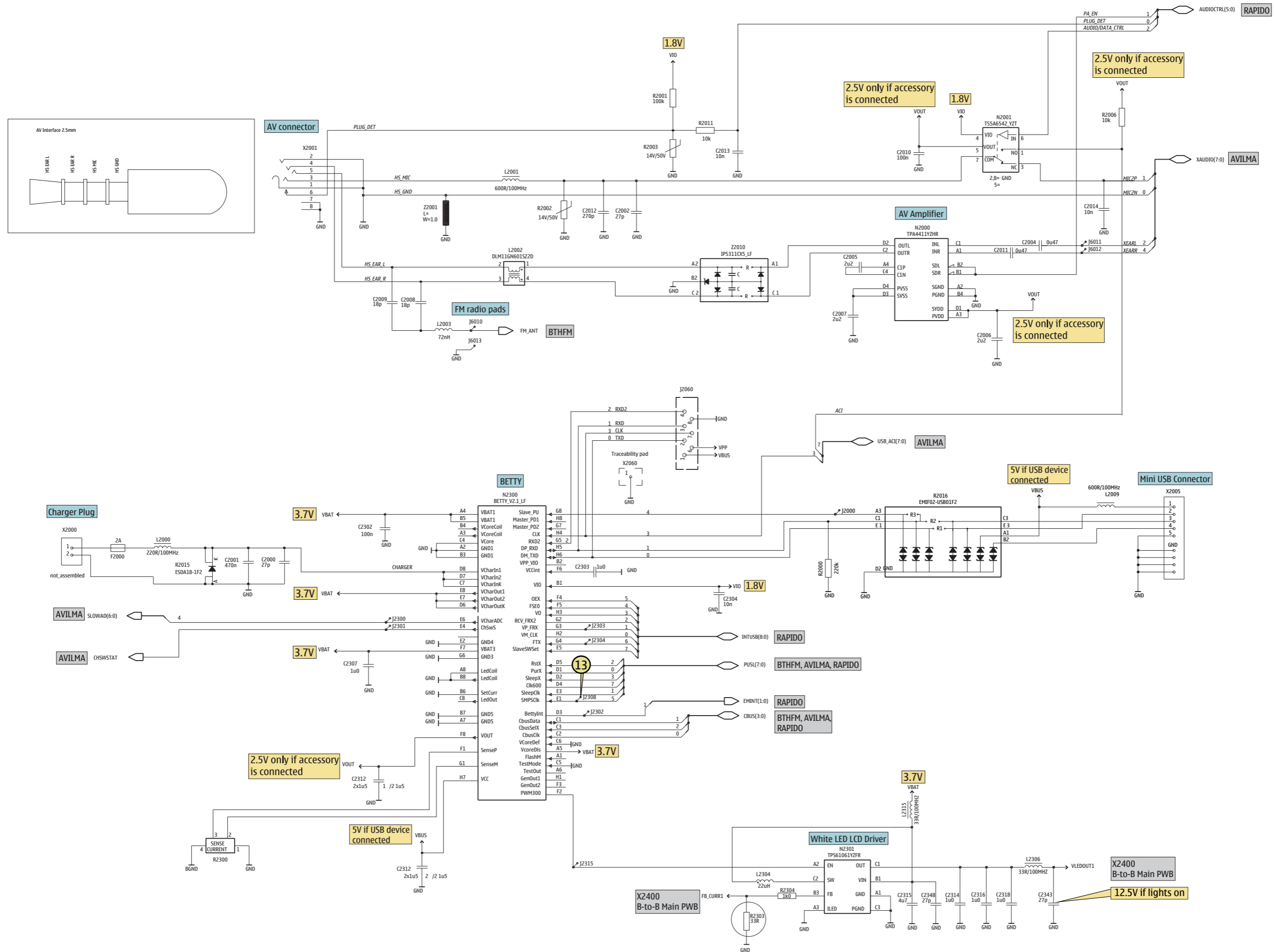

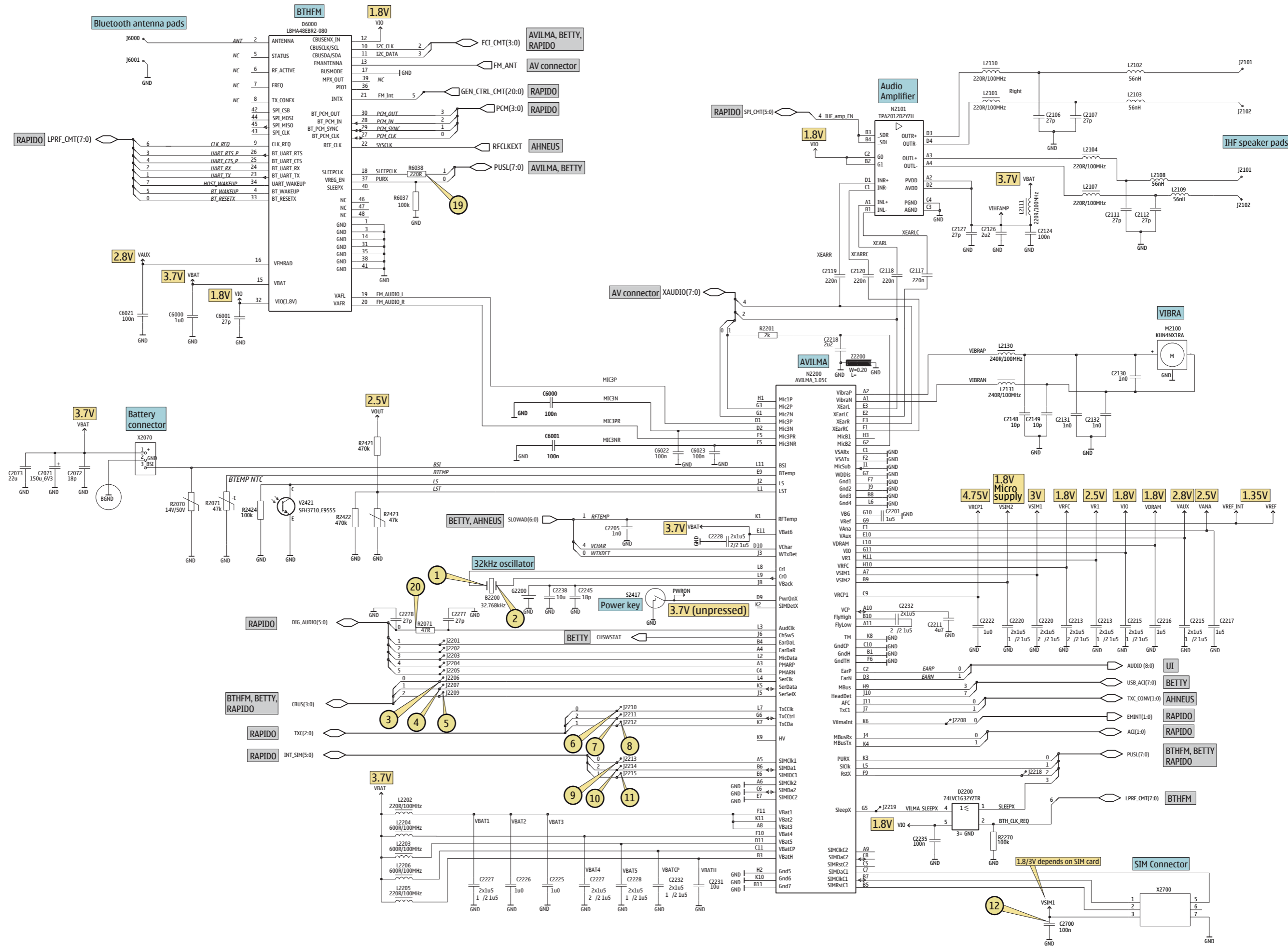

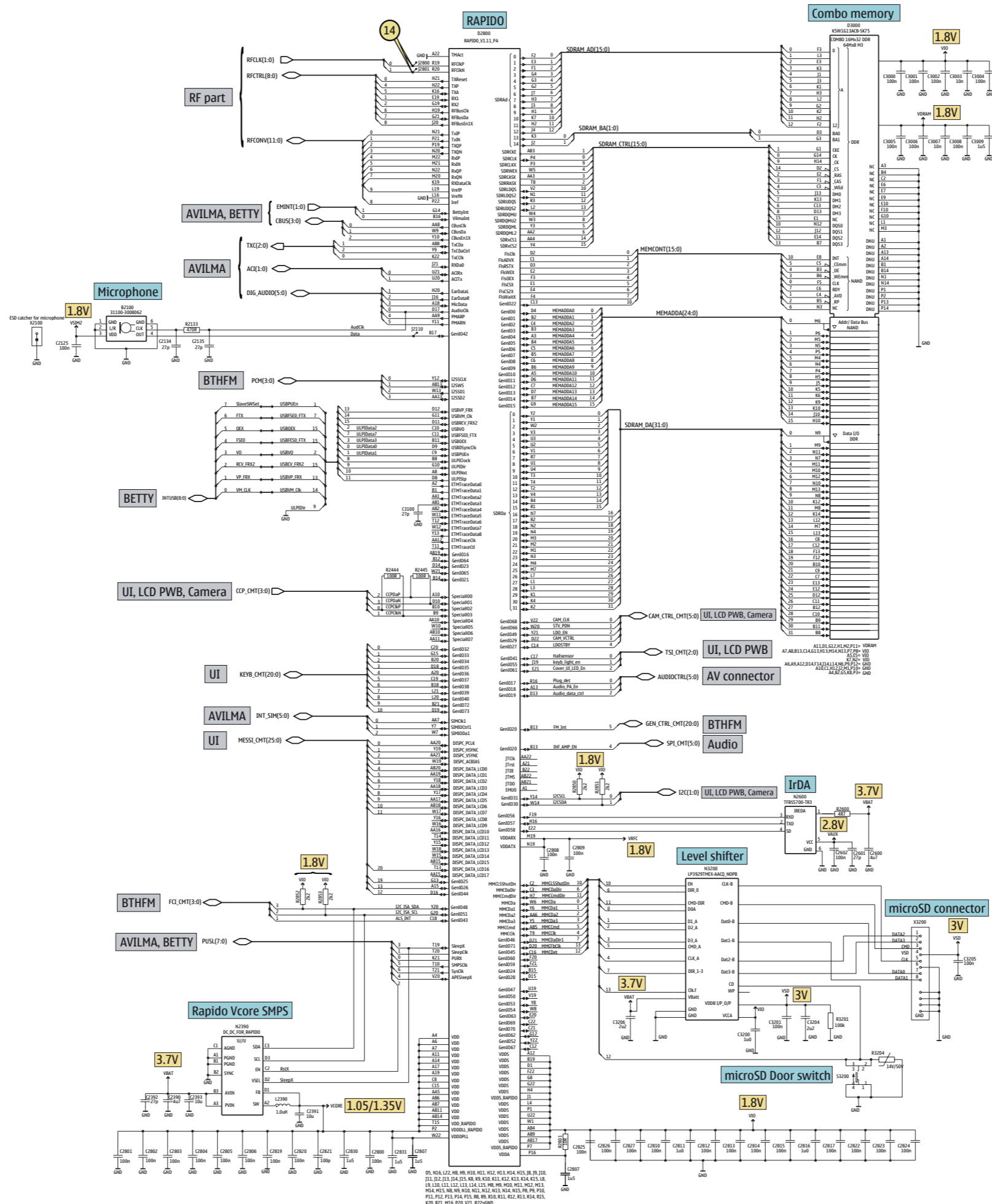

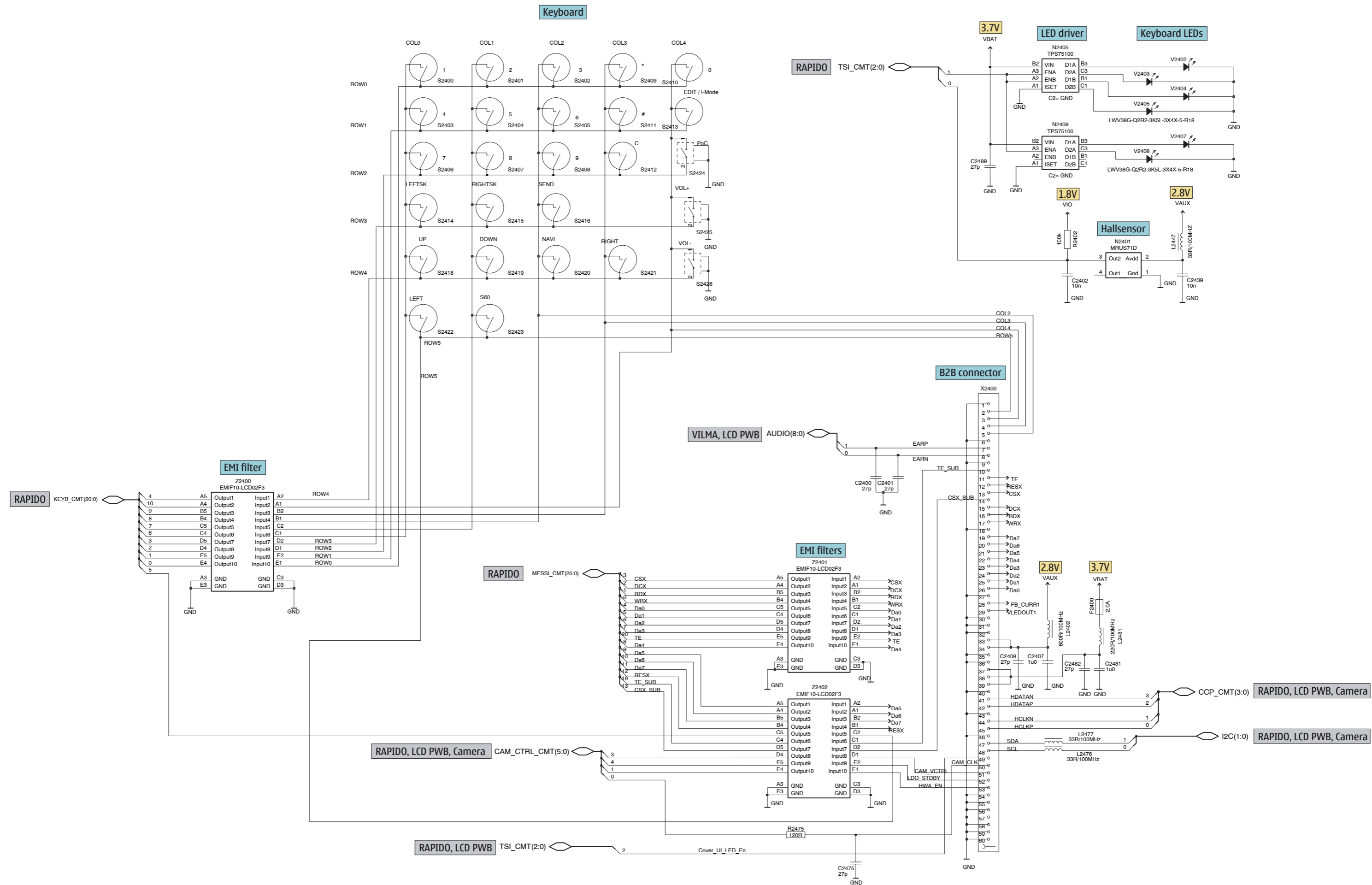

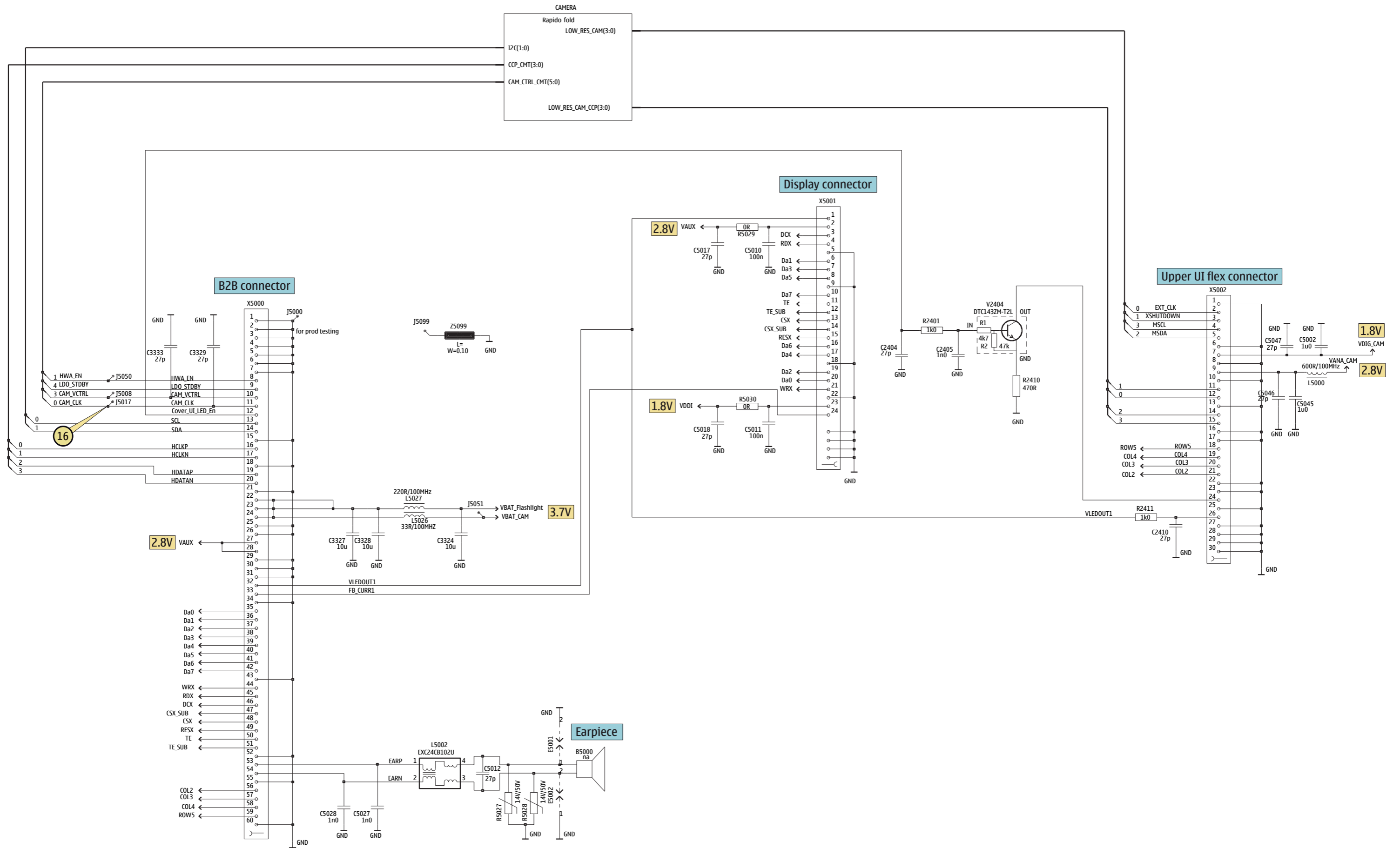

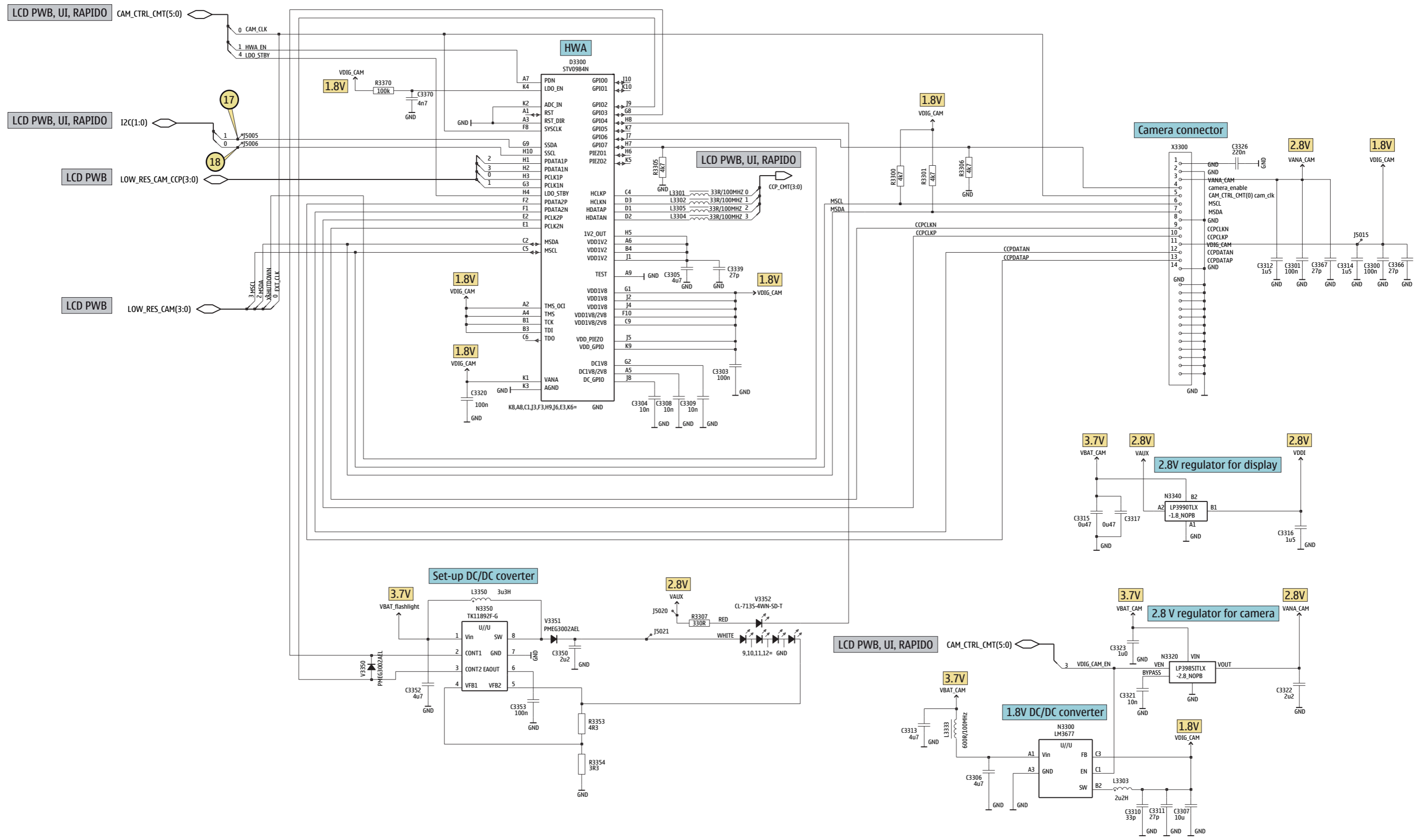

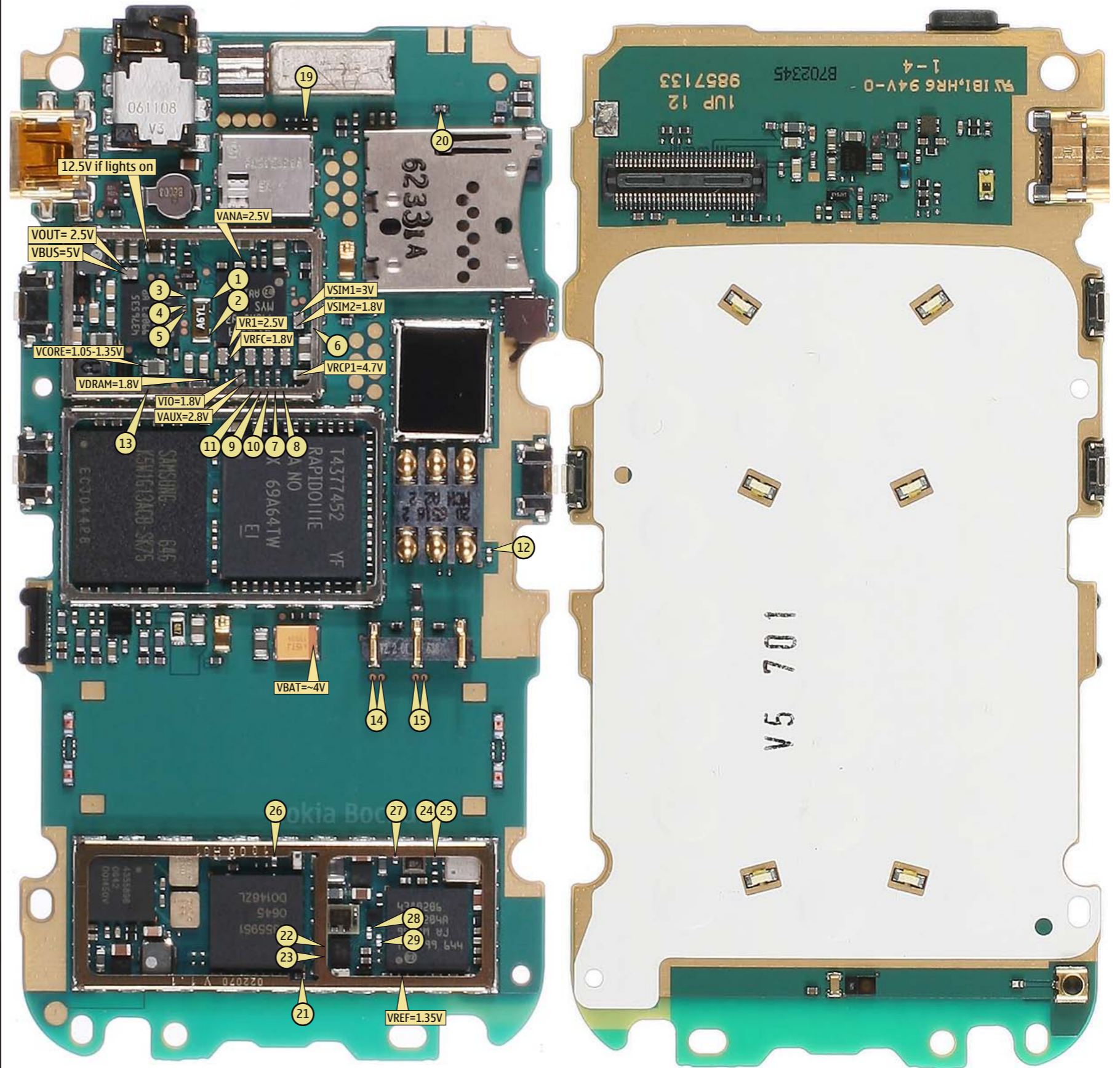
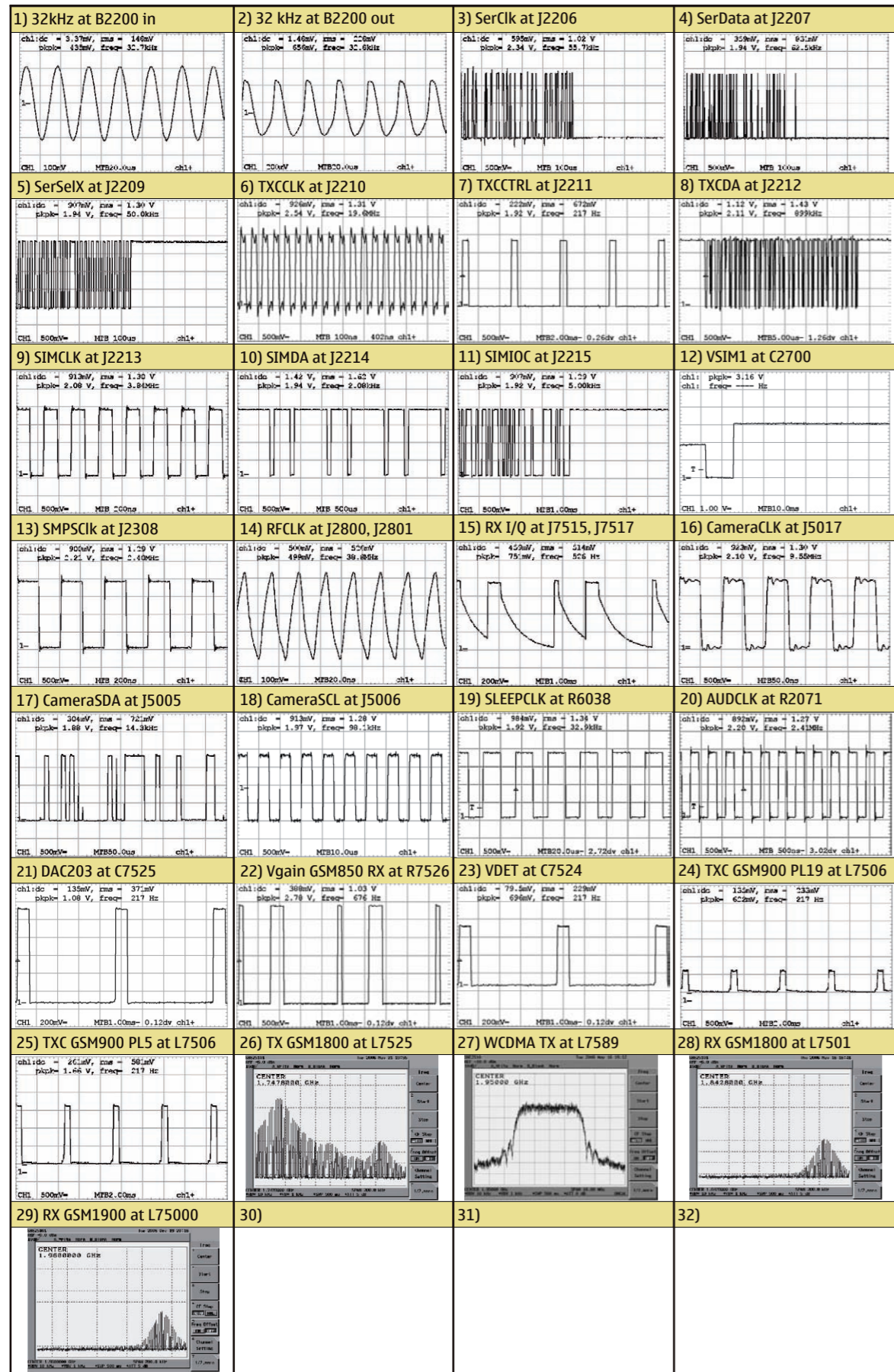

B	C2312	O3	C3100	M7	J2208	O6	L2476	Q9	R2424	P4	
B2100	C5	C2314	O3	C3200	M8	J2209	N4	L2477	Q8	R2444	M6
B2200	N4	C2315	N2	C3201	N8	J2210	N6	L2481	Q6	R2445	M6
C	C2316	O3	C3204	N8	J2211	M5	L7500	C7	R2475	J7	
C2001	Q9	C2318	O3	C3205	N9	J2212	M6	L7501	C7	R2600	I4
C2002	P5	C2348	O2	C6000	Q6	J2214	M5	L7503	H5	R2850	I6
C2004	Q5	C2390	N2	C6001	P4	J2215	M5	L7506	E8	R2851	I6
C2005	Q6	C2391	M3	C6021	Q6	J2218	M3	L7510	E5	R2852	I7
C2006	Q5	C2392	N2	C6022	O5	J2219	O4	L7525	E6	R2853	L7
C2007	Q6	C2393	N3	C6023	O5	J2300	N4	L7527	C5	R3201	N8
C2008	Q5	C2400	P9	C7500	D9	J2301	N4	L7528	C5	R3204	N9
C2009	Q5	C2401	P9	C7507	D8	J2302	M4	L7529	C6	R6037	L7
C2010	P6	C2402	Q4	C7513	C9	J2303	O4	L7530	C9	R6038	Q6
C2011	Q5	C2407	Q6	C7518	C7	J2304	O3	L7540	C4	R7501	D9
C2012	P5	C2408	Q7	C7519	C9	J2308	M3	L7550	C2	R7502	C8
C2013	Q4	C2439	Q4	C7520	C9	J2315	N2	L7565	M9	R7503	C8
C2014	P6	C2475	J7	C7521	C5	J2800	H7	L7588	D8	R7509	D8
C2071	H6	C2481	Q6	C7523	E5	J2801	H7	L7589	E8	R7522	D7
C2072	I8	C2482	Q7	C7524	C6	J3107	N7	L7590	E7	R7526	C6
C2073	H5	C2489	N7	C7525	C6	J3108	M7	L7591	C3	R7541	C2
C2106	H2	C2600	I4	C7543	C3	J3109	M7	L7592	D7	R7543	D3
C2107	H2	C2601	H2	C7544	C3	J3111	M7	L7599	C3	R7544	C3
C2111	H4	C2602	H2	C7545	C3	J3112	N7	M	R7565	M9	
C2112	H3	C2700	J9	C7547	C3	J3113	M7	M2100	R6	S	
C2117	I3	C2800	J4	C7548	D2	J3121	M7	N	S2424	K10	
C2118	I3	C2801	L6	C7549	D4	J6000	R9	N2000	Q5	S2425	N1
C2119	I3	C2802	I6	C7550	C2	J6001	S9	N2001	P6	S2426	K1
C2120	I2	C2803	L6	C7553	D4	J6010	Q5	N2100	I3	S3200	N10
C2124	I2	C2804	L5	C7566	M9	J6011	Q5	N2200	N5	T	
C2125	C6	C2805	L6	C7567	M9	J6012	Q5	N2300	N3	T7502	E6
C2126	H3	C2806	I5	C7580	C9	J6013	Q5	N2301	O2	T7580	C7
C2127	H3	C2807	I7	C7581	C9	J7515	H8	N2390	M3	V	
C2130	Q8	C2808	K7	C7582	C9	J7517	H8	N2401	Q4	V2402	N4
C2131	Q7	C2809	K7	C7583	C8	J7590	B2	N2405	N7	V2403	K7
C2132	Q7	C2810	J4	C7586	C7	J7591	C2	N2409	N7	V2404	N7
C2134	I6	C2811	L5	C7587	C7	J7592	C2	N2600	I1	V2405	K4
C2135	I6	C2812	I6	C7590	E7	L	N3200	M8	V2407	D7	
C2148	Q7	C2813	L6	C7591	D7	L2000	R10	N7505	D8	V2408	D4
C2149	Q7	C2814	K7	D	L2001	P5	N7520	D5	V2421	P3	
C2201	M5	C2815	I5	D2200	O4	L2002	Q5	N7540	D3	X	
C2205	O5	C2816	L7	D2800	K6	L2003	P5	N7541	C3	X2001	R3
C2211	M6	C2817	I5	D3000	K3	L2009	P3	N7590	D7	X2005	Q2
C2213	M5	C2818	I6	D6000	P5	L2101	H2	R	X2060	Q10	
C2215	M5	C2819	I5	F	L2102	F2	R2000	P3	X2070	H8	
C2216	M5	C2820	L5	F2000	R10	L2103	G2	R2001	Q3	X2100	C6
C2217	O5	C2821	K7	F2400	Q6	L2104	H4	R2002	P5	X2400	P8
C2218	O5	C2822	L7	G	L2107	H3	R2003	Q3	X2410	I5	
C2220	N6	C2823	L6	G2200	P4	L2108	G9	R2006	P6	X2411	O7
C2222	M6	C2824	J7	G7501	E9	L2109	F9	R2011	Q3	X2700	K8
C2225	M4	C2825	K4	J	L2110	H2	R2015	R9	X3200	P9	
C2226	M4	C2826	L4	J2000	P2	L2111	I2	R2016	P3	X7501	C2
C2227	M5	C2827	J4	J2060	P7	L2130	Q7	R2070	I8	Z	
C2228	M5	C2830	L4	J2101	H9	L2131	Q7	R2071	R8	Z2010	Q5
C2231	O6	C2831	I7	J2102	F9	L2202	M4	R2133	I6	Z2400	L8
C2232	M6	C3000	L4	J2103	F2	L2203	M5	R2201	O5	Z2401	L9
C2235	O4	C3001	L3	J2104	H2	L2204	M5	R2270	O4	Z2402	L8
C2238	Q4	C3002	I4	J2110	I6	L2205	O6	R2271	O6	Z7501	C7
C2245	O4	C3003	I3	J2201	N6	L2206	M6	R2300	I8	Z7503	D7
C2277	O6	C3004	I3	J2202	N6	L2304	O2	R2303	P7	Z7504	D7
C2278	L6	C3005	L3	J2203	O4	L2306	O4	R2304	P7	Z7540	E4
C2302	M4	C3006	L3	J2204	O6	L2315	N2	R2402	Q4	Z7541	D4
C2303	N3	C3007	I2	J2205	N6	L2390	M2	R2421	P4	Z7580	C7
C2304	M4	C3008	L4	J2206	N4	L2402	Q6	R2422	P4	Z7582	E8
C2307	N3	C3009	I3	J2207	N4	L2447	Q4	R2423	P4		

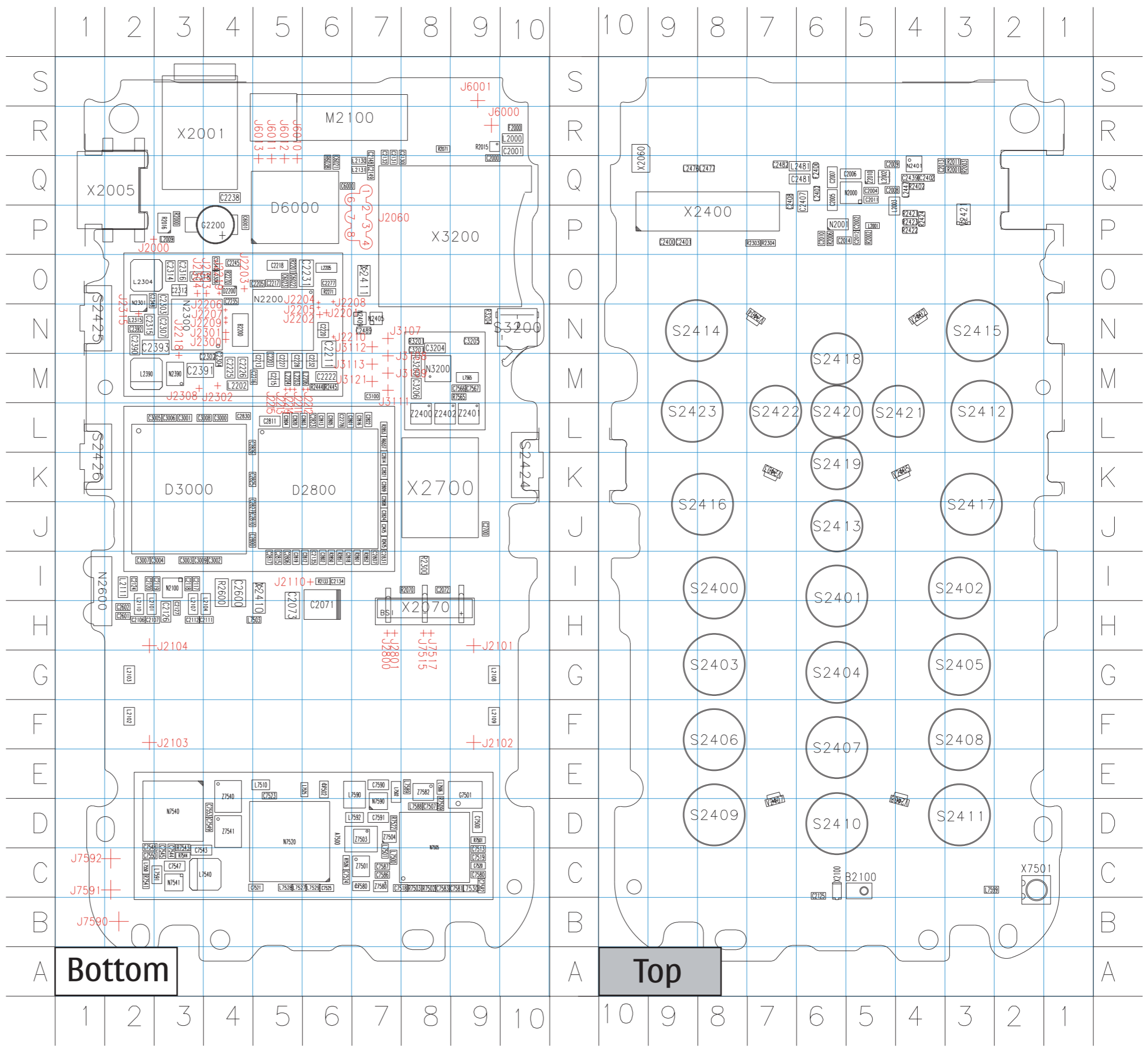

C	J5005	O8	
C2404	N3	J5006	O8
C2405	B4	J5008	P7
C2410	C5	J5015	O7
C3300	N6	J5017	N8
C3301	Q5	J5020	O8
C3303	O8	J5021	N4
C3304	N8	J5050	N7
C3305	M7	J5051	P7
C3306	P7	J5099	Q3
C3307	O7	L	
C3308	M7	L3301	M6
C3309	N7	L3302	M6
C3310	O8	L3303	O8
C3311	O8	L3304	M6
C3312	Q5	L3305	M6
C3313	P7	L3333	P7
C3314	N6	L3350	O3
C3315	C9	L5000	A5
C3316	B9	L5002	B4
C3317	C8	L5026	N4
C3320	O7	L5027	N2
C3321	O7	N	
C3322	O7	N3300	O7
C3323	O7	N3320	O7
C3324	P2	N3340	B8
C3326	Q6	N3350	O2
C3327	N3	R	
C3328	N3	R2401	C4
C3329	N3	R2410	C4
C3333	N2	R2411	C5
C3339	M7	R3300	M7
C3350	O3	R3301	M7
C3352	P3	R3305	M8
C3353	O2	R3306	M8
C3366	N6	R3307	O3
C3367	Q5	R3353	P2
C3370	O7	R3354	P2
C5002	A5	R3370	O7
C5010	B8	R5027	A4
C5011	B9	R5028	A4
C5012	B4	R5029	B8
C5017	B8	R5030	B9
C5018	B9	V	
C5027	C3	V2404	B4
C5028	C3	V3350	P2
C5045	A4	V3351	O3
C5046	A5	V3352	P2
C5047	A5	X	
D	X3300	P5	
D3300	N7	X5000	M3
J	X5001	B8	
J5000	P7	X5002	B5

